

Reconstruction of Westmount Community Gardens

Project Overview

Westmount's community gardens located on the north portion of the Westmount athletic grounds between Hallowell and Hillside are an important collective space for residents to grow vegetables. However, the infrastructure of the gardens including the fencing, borders and water systems were in an irreparable state. The city therefore decided to take the opportunity and upgrade not only these key features but the design of the garden beds by raising them and adding a keyhole for easy access. The decision to remove a few select trees and shrubs to open up the space and allow for more appropriate access was adopted as well.

Plans

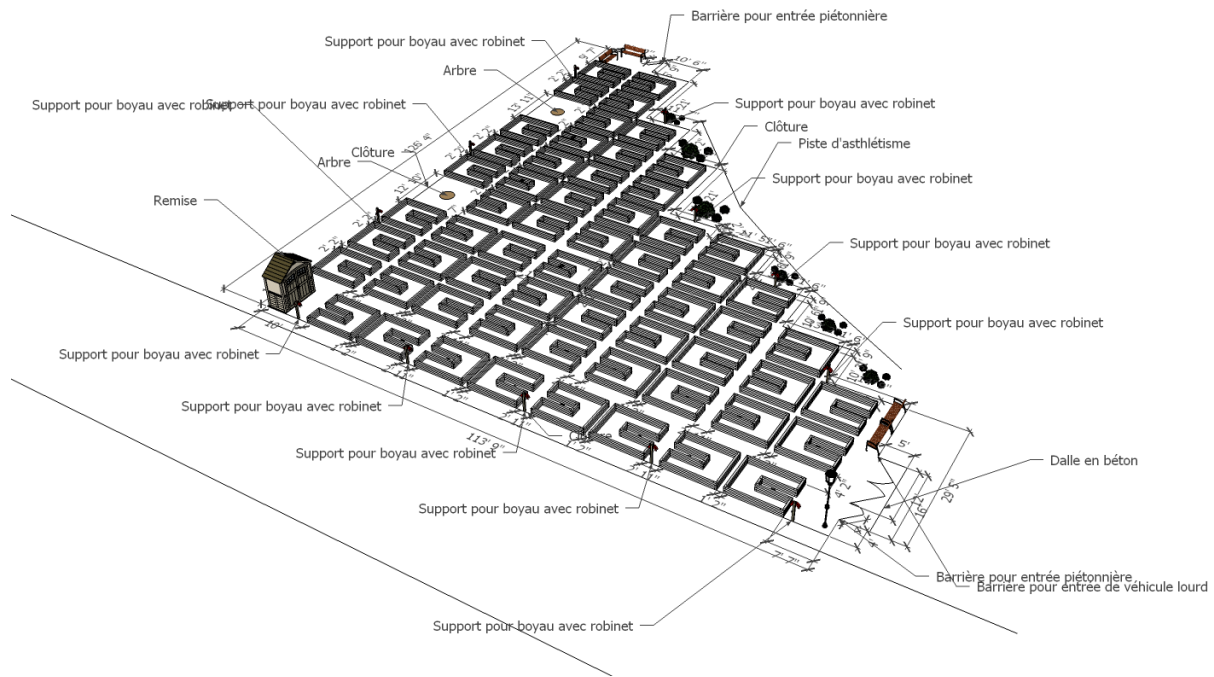

Figure 1: Isometric view of Hillside community garden

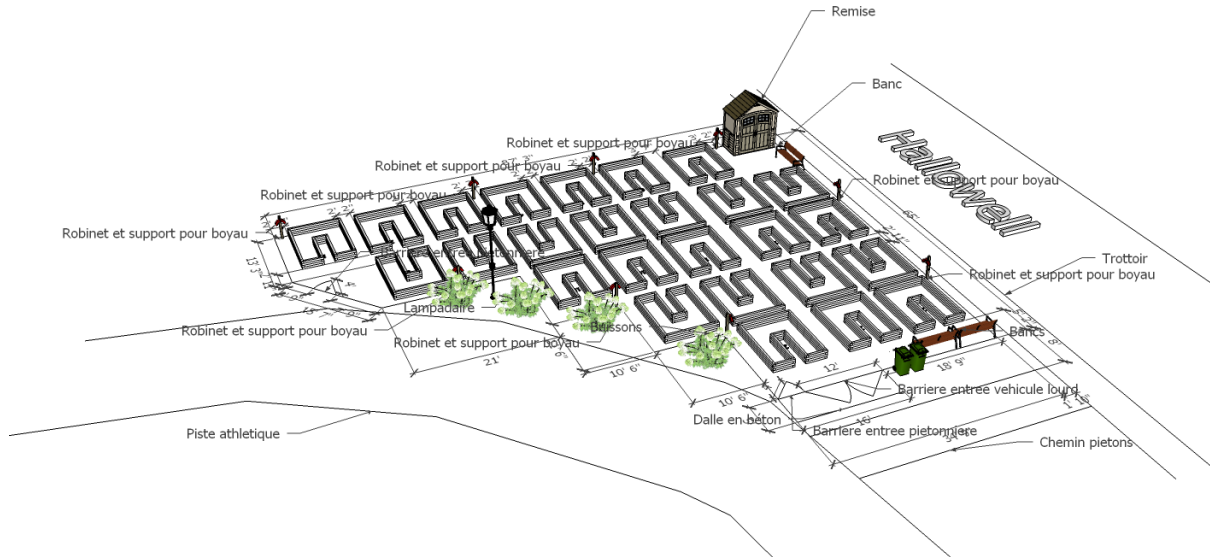

Figure 2: Isometric view of Hallowell community garden

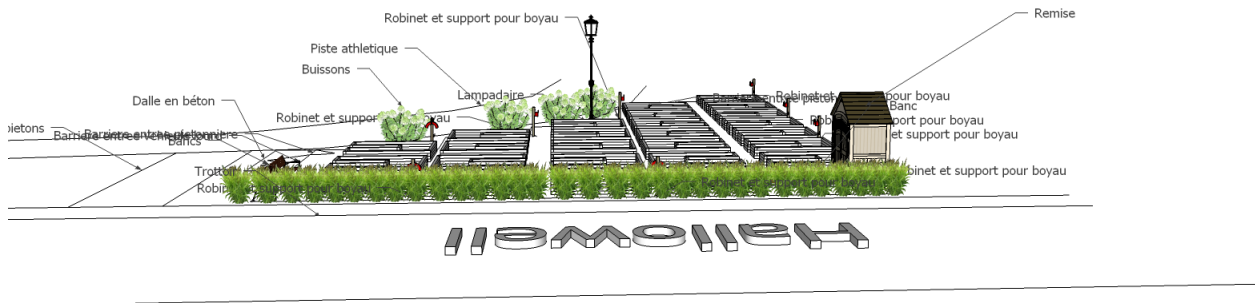

Figure 3: Isometric view from opposite of Hallowell

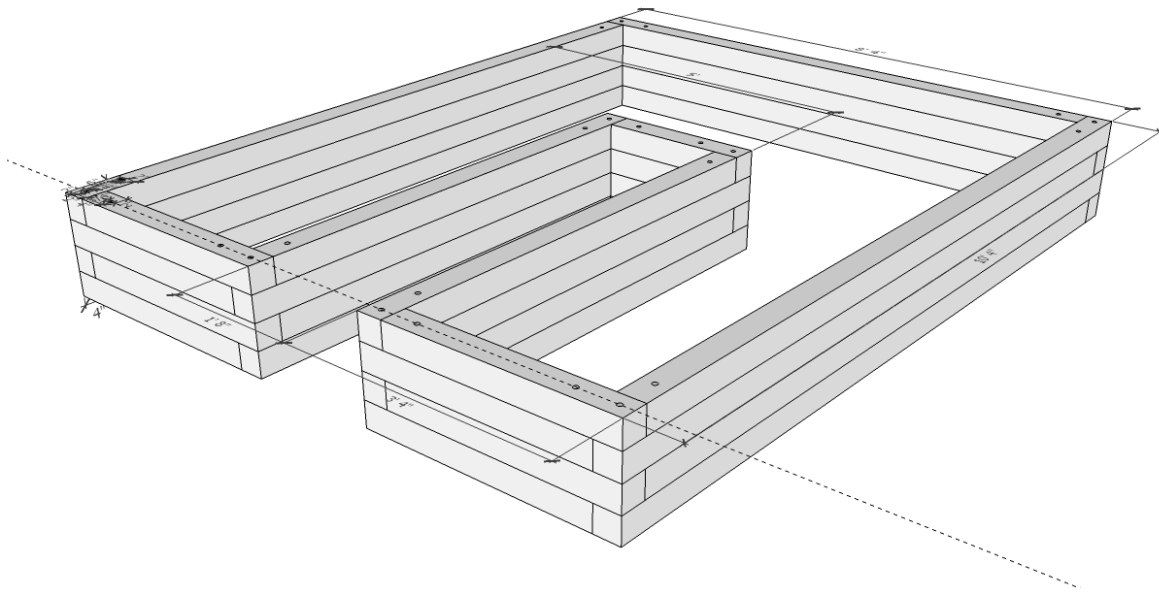

Figure 4: Isometric view of individual keyhole garden

Project Details

The following repairs and upgrades are part of the Reconstruction of Westmount Community Gardens project:

- Removal of existing ground level gardens and construction of raised bed gardens:
 - The same number of garden plots will remain
 - All gardens will be of equal dimensions following a rectangular keyhole design as a single bed of 10 feet by 9 feet with a height of 18 inches filled with a nutrient-rich balanced soil mix
 - Raised beds will be made from wood and will have numbers affixed

- Increasing the amount of available water access points:
 - More spigots will be made available to facilitate watering
 - The new water lines will be installed in a location that allows for easy access in the case of leaks without disturbing the garden beds

- A new shared shed and compost station will be installed for each garden

- Clusters of shrubs and sedges will be planted on the public side of the Community Garden fence:
 - These plantings will serve the purpose of attracting pollinators needed for fruiting in the gardens
 - They will also be located outside of the Community Garden fence (see plans) and will be maintained by the city's horticulture team

- A new fence will be installed that will match the existing chain-link fence along the Westmount High school parking lot

Timeline

Preparations (COMPLETED)

The city provided pots for transplanting and assisted those with reduced mobility in the transplanting process. This step started Monday the 18th of September 2017. Pots, markers and tape were made available near the shed space of each garden for this purpose.

These potted plants were moved over to the greenhouses between the 2nd and 4th of October between 9am and 11am. At this point, people who had difficulties transplanting received help from the city's greenhouse staff.

Transplanting of the following plants was not accepted:

1. Virginia creeper
2. Jerusalem artichoke
3. Japanese knotweed
4. Bugleweed

Project breakdown

Phase 1 of the work was accomplished October 9th, 2017 and included the following (COMPLETED):

- Removal of existing fence
- Removal of existing gardens and borders
- Grading of the garden areas to achieve a uniform surface

Phase 2 of the work will be completed by **the end of June, 2018** and will include the following:

- Construction of raised beds and filling with soil
- Installation of tool sheds
- Relocation of waterlines
- Installation of new fence
- Return of perennials overwintered at the Westmount Greenhouses

Phase 3 will be completed **before the end of November 2018** and will include the following:

- Planting of shrubs and sedges in strategic locations along the fence (see plans)

You will be able to enter the gardens to begin planting by the end of June and replant the perennials that have been overwintered at the Westmount Greenhouses. Please note however, that no further planting of non-edible ornamental perennials will be permitted in the future.

Should you have any questions or concerns pertaining to this project, we ask that you please visit the city website at the following address: www.westmount.org/gardens and kindly fill out the form made available for this purpose. If you are having difficulties accessing the internet, please visit the Westmount Public Library or Victoria Hall and ask for assistance to fill out the online form at the reception.

Sincerely,
Nicolas Mory

Superintendent of Horticulture and Arboriculture
Westmount Public Works